

Rail Mounting Kit Installation Instructions

for the ProCurve Series zl Switches

The zl switches can be mounted with the optional Rail Mounting Kit (5070-0145) for shipment in an HP 10000 series rack. These rails stabilize the switch, so the rack or cabinet can be shipped without removing the switch. However, the power supplies must be removed from the chassis before shipping.

Note

The power supplies must be removed from the chassis before shipping in a rack.

Even though the illustrations show a Switch 5406zl, the instructions apply to all zl chassis models.

1. Use a posi-drive screwdriver, two included 8-mm M6 screws, and two included M6 cage nuts to attach each rail to the rack or cabinet as shown in the following illustration. Ensure that the screws are at the same level in each upright.

Devices installed in a rack or cabinet should be mounted as low as possible, with the heaviest device at the bottom and progressively lighter devices installed above.

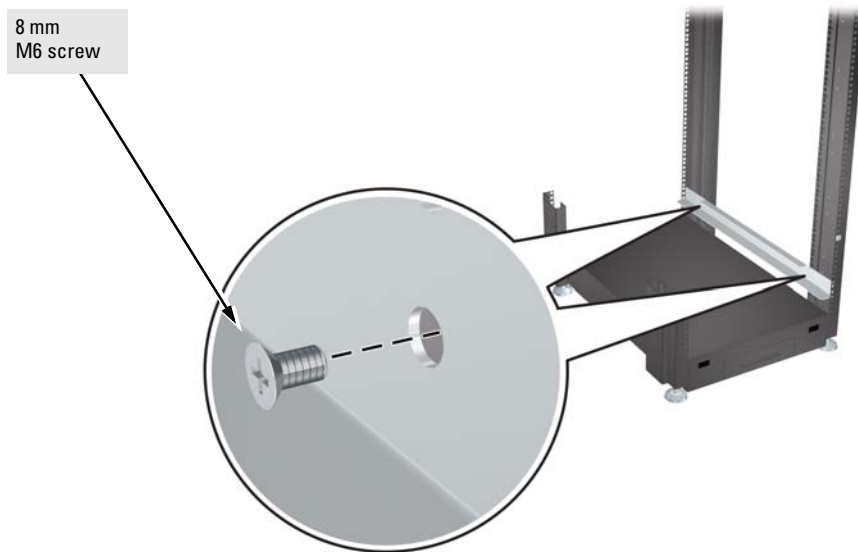

Figure 1. Attaching Rails to a Rack

- Use a #1 Phillips (cross-head) screwdriver and two included 8-mm M4 flat head screws to attach a hold-down bracket to the chassis as shown in the following illustration. Ensure that each hold-down bracket is positioned at the lower rear corners of the chassis.



Figure 2. Attaching Hold-Down Bracket

- Use a #1 Phillips (cross-head) screwdriver to attach the mounting brackets to the switch with the included 8-mm M4 screws. Each bracket is attached with four screws as shown in figure 3.



Figure 3. Attaching Rack Mounting Brackets

- Slide the switch onto the rails in the rack until the mounting brackets are flush with the front of the cabinet.



Figure 4. Notches in Bracket Being Installed

5. Install the four number 12-24 screws (included in the mounting bracket kit) into the upper and lower holes in each bracket. Tighten these screws.

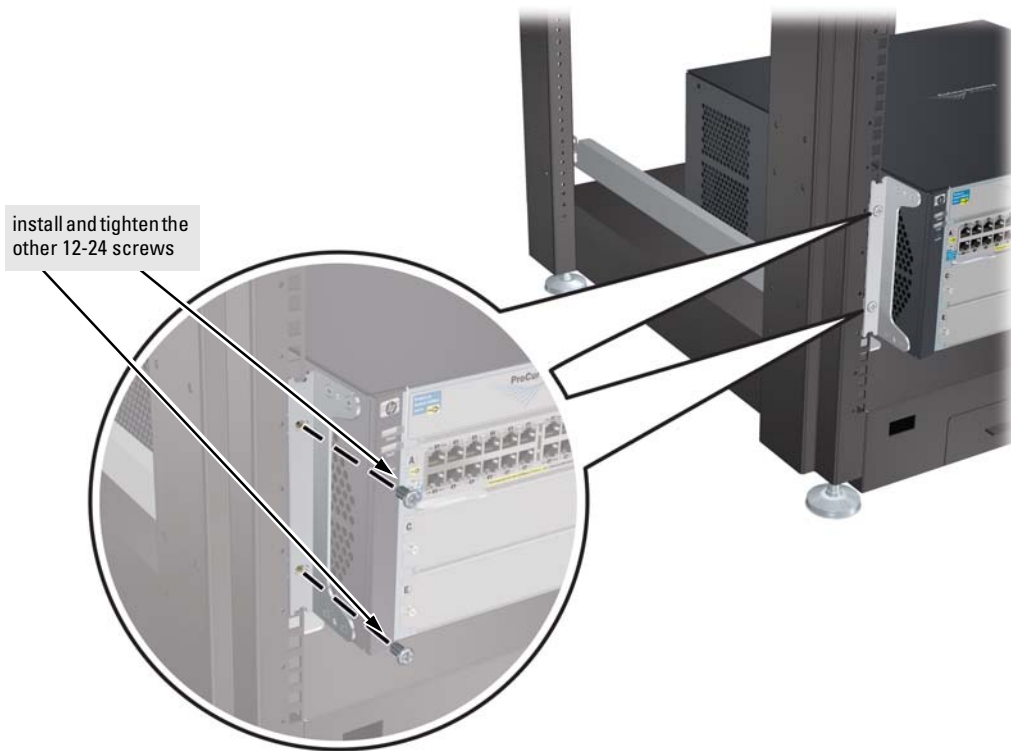

Figure 5. Installing screws in brackets

© Copyright 2006, 2007 Hewlett-Packard Development Company, LP. All rights reserved. The information contained herein is subject to change without notice.

This document contains proprietary information, which is protected by copyright. No part of this document may be photocopied, reproduced, or translated into another language without the prior written consent of Hewlett-Packard.

Technical information in this document is subject to change without notice.



Part Number: 5991-8559
August 2007
Printed in Singapore

